



BEVERAGE-AIR

Project: _____	AIA#
Item: _____	
Location: _____	SIS#
Approved: _____	

HBR49HC BOTTOM MOUNT DUAL TEMPERATURE REFRIGERATOR/FREEZER

DUAL TEMPERATURE REFRIGERATOR/FREEZER

MODEL:
HBRF49HC-1-A

HBRF49HC Solid Door Bottom Mount Reach-In
Hydrocarbon Series



5 Year Parts/Labor Warranty Available
7 Year Compressor Warranty

CABINET CONSTRUCTION

- Stainless steel front, side, and grille (galvanized back & bottom)
- Stainless steel interior
- Full electronic control with one-touch defrost
- Dual temp refrigerator/freezer units provide two different operating temperature zones for different types of products
- Left: refrigerator section
- Right: freezer section
- One-piece grille allows easy removal/installation for preventative maintenance
- Door locks standard
- Self closing doors, 120° stay open feature with spring-loaded style hinges
- Snap-in magnetic door gaskets for easy cleaning and replacement
- Ten (10) heavy-duty epoxy coated wire shelves
- LED lighting standard
- 6" Heavy-duty casters with (2) brakes
- Certified for open food product

OPTIONS & ACCESSORIES

- 3 Year parts/labor standard, additional 2 year warranty available
- Epoxy shelves
- Shelf clips
- 3" Caster or 6" legs
- Wine temperature control
- Door swing orientation (at time of order)
- Remote option* (see note on back page)

REFRIGERATION SYSTEM

- Uses environmentally friendly, energy efficient R290 refrigerant, and meets all regulatory requirements for CARB, SNAP, DOE & more
- Adaptive defrost
- Epoxy coated evaporator coil
- Refrigerator maintains product temperatures between 36°F to 38°F
- Freezer maintains product temperature to -10°F



 Please verify qualifying units by visiting:
www.energystar.gov/cfs

3779 Champion Blvd., Winston-Salem, NC 27105
1-888-845-9800 Fax: 1-336-245-6453
Beverage-Air.com Sales@bevair.com



BEVERAGE-AIR

Dual Temp Bottom Mount Reach-In Solid Door Refrigerator / Freezer Model: HBRF49HC-1-A

MODEL	HBRF49HC-1-A
EXTERNAL DIMENSIONAL DATA	
Width Overall	52"
Depth Overall (with handles)	33 3/4"
Height Overall (with casters)	84"
Number of Doors	2
Depth with Door Open 90°	56 1/8"
Door Openings (in)	22 3/4" x 52 5/8"
INTERNAL DIMENSIONAL DATA	
NET Capacity (cubic ft.)	(R) 21.01 (F) 21.01
Internal Width Overall (in)	(2) 23"
Internal Depth Overall (in)	27"
Internal Height Usable (in)	55"
Number of Doors/Shelves	10
ELECTRICAL DATA	
Full Load Amperes	(R) 2.88 (F) 6.34
REFRIGERATION DATA	
Horsepower	(R) 1/4 (F) 3/4
Capacity (BTU/Hr)	(R) 1702 (F) 2097
Heat Rejection (BTU/Hr)	4848
Charge (lbs/grams/ounce)	(R) 0.1984 / 90 / 3.17 (F) 0.2094 / 95 / 3.35
SHIPPING DATA	
Gross Weight - Crated	790 lbs
Height - Crated	88"
Width - Crated	53"
Depth - Crated	35"

*NOTE: Remote units are field wired and come with 6" legs.
Refrigerant must be specified at time of order.

Model Views

Required Clearance: Bottom & Rear 3"

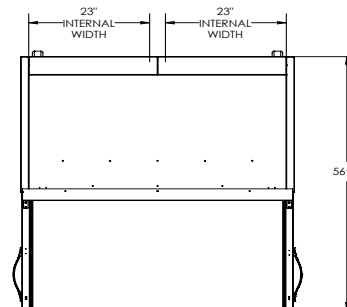

PLAN VIEW

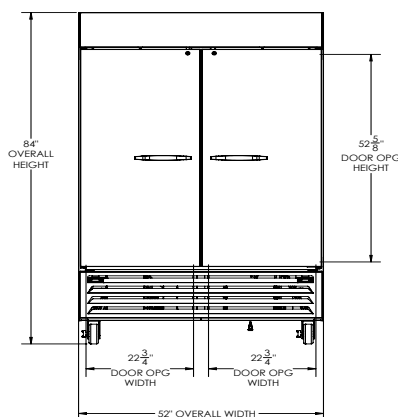

ELEVATION VIEW

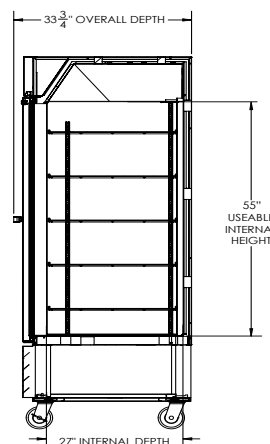

SIDE VIEW

ELECTRICAL CONNECTION



115/60/1
(2) NEMA 5-15P

Unit pre-wired at factory
and include 8' long cord
and plug set.



3779 Champion Blvd., Winston-Salem, NC 27105 1-888-845-9800 Fax: 1-336-245-6453 Beverage-Air.com Sales@bevair.com

an Ali Group Company



The Spirit of Excellence